



BREAKERS & ATTACHMENTS

BREAKER MODEL

65 TN

HIGH PERFORMANCE

Membrane and Accumulator

With its highly resilient membrane and tough accumulator, our breakers impact with the same energy on every single stroke, thus providing maximum efficiency even when working on the hardest materials.

Tunnel Bracket

Tunnel series hydraulic breaker brackets were designed specifically for tunnel conditions to ensure effective and secure operation in a horizontal position.

MORE DURABLE

Hydraulic Cushioning

The hydraulic cushioning function on hydraulic breakers prolongs the lifetime of the components by preventing the piston from impacting the cylinder.

Wearing Plates

Our breakers have longer lifetime thanks to their highly resilient wearing plates which were specially designed for operating conditions.

Thrust Ring

Thrust rings are designed specifically for harsh tunnel operations and are reinforced with high-strength steel. These properties ensure that the thrust ring is highly resistant to impacts and wearing.

MORE RELIABLE

Minimum Vibration

Minimum vibration and maximum performance with our excellent impact absorbant vibration buffers and polyurethane-covered tie-rods.



TECHNICAL INFORMATION

65 TN

Operating weight (a) kg	750
Oil Flow l/min	60~110
Impact Rate (b) bpm	400~730
Operating Pressure (c) bar	125~130
Input power (d) kW	12.5~23.8
Relief Pressure bar	190
Back Pressure Max. bar	8
Tool Diameter mm	95
Noise Level (e) LWA (dB)	128
Carrier Weight (f) t	8~14

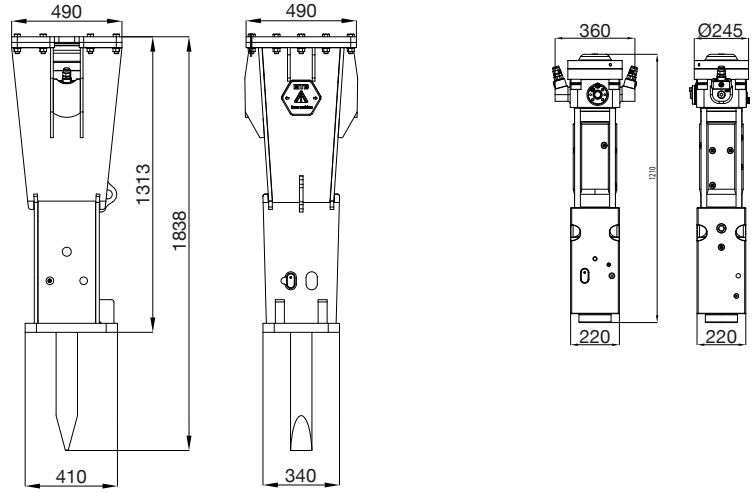

(a) It includes the approximate weight of the breaker, bracket, standard tool and hose weights.

(b) Actual impact frequency depends on the oil flow, oil viscosity, temperature and the material to be broken.

(c) Actual pressure depends on the oil flow, oil viscosity, temperature, material to be broken and the return pressure.

(d) Input power directly effects fuel consumption. Low input power (kW) requirement means low fuel consumption.

(e) Guaranteed sound power testing results according to directive 2000/14/EC (Guaranteed dB(A)=Measured Value +3 dB).

(f) If the carrier machine is out of the optimum range, ask the carrier machine manufacturer for allowed attachment weight.

TOOL PROPERTIES

	Pyramid	Moil	Chisel	Blunt
Operating Principle				
Key Properties	<ul style="list-style-type: none"> ○ Breaking in four directions ○ General demolition 	<ul style="list-style-type: none"> ○ Breaking in all directions ○ Suitable for general use 	<ul style="list-style-type: none"> ○ Breaking in two directions ○ Suitable for general purpose by demolition 	<ul style="list-style-type: none"> ○ Good energy transfer ○ Demolition – Impact breaking

SPECIAL TOOLS

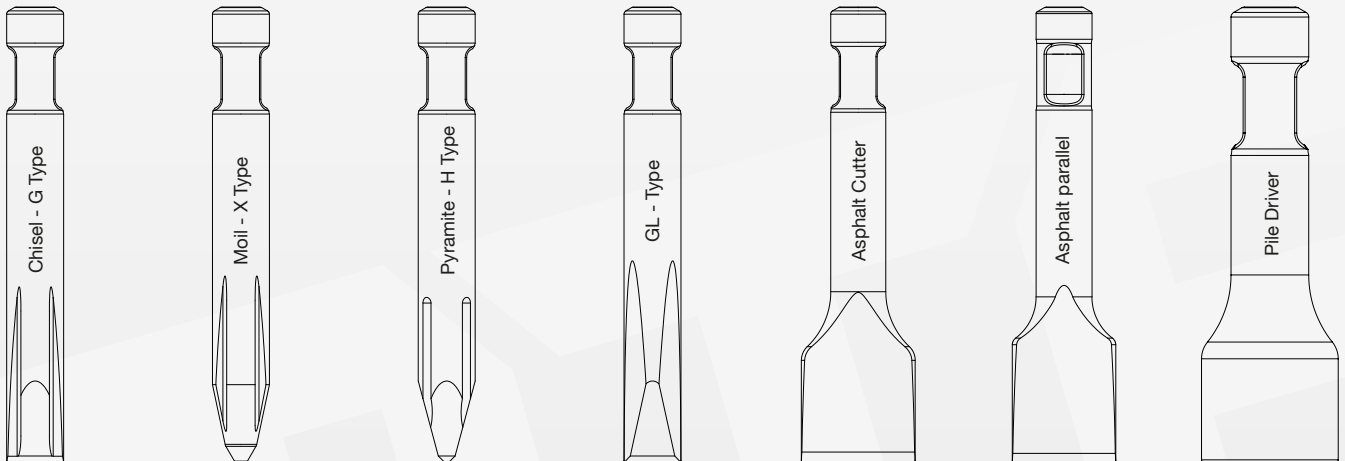

Rev. 220324



Factory

Bahçelievler OSB Mh. 11. Cd. No: 4A

59510 Kapaklı / Tekirdağ - TURKEY

+90 282 768 25 00

www.mtbbreakers.com - info@inanmakina.com



WARNING!: The visuals and the information in this brochure are standard or optional depending on the version of the product.

İNAN MAKİNA A.Ş. saves the right to modify the values and designs shown in this brochure without notice.