



BREAKERS & ATTACHMENTS

## BREAKER MODEL

# 125 TN

### OUR PERFORMANCE LINE

#### Piston Design

It has a perfect piston design and with its higher impact frequency, it is suitable for vertical and horizontal operations.

#### Membrane and Accumulator

With its highly resilient accumulator and membrane, our breakers impact with the same energy on every single stroke, thus providing maximum efficiency even when working on the hardest materials.

### MORE DURABLE

#### C-Type Chassis

Its outer design is completely different and is supported with wearing-resistant Hardox® plates. C-type housing provides maximum durability even in the toughest conditions.

#### Wearing Plates

Our breakers have longer lifetimes thanks to their highly resilient tall type wearing plates which were specially designed for the toughest operating conditions.

#### Dual Retainers

Dual retainer design makes sure that the tool impacts with more balance.

### MORE RELIABLE

#### Tie-rods

Our tie-rods are suitable for the harsh conditions of the tunnel environment and they make long and uninterrupted operation possible.

#### Minimum Vibration

Minimum vibration and maximum performance with our excellent impact absorbant vibration buffers and polyurethane-covered tie-rods.

#### Hydraulic Cushioning

If the breaker blank-fires during operation, thanks to our hydraulic cushioning feature the piston won't hit the cylinder, therefore prolonging the lifetimes of the components.



**inan makina**®  
SANAYİ VE TİCARET A.Ş.





# TECHNICAL INFORMATION

## 125 TN

Operating weight (a) kg	1300
Oil Flow l/min	80~130
Impact Rate (b) bpm	460~760
Operating Pressure (c) bar	135~140
Input power (d) kW	18~30.3
Relief Pressure bar	200
Back Pressure Max. bar	8
Tool Diameter mm	115
Noise Level (e) LWA (dB)	127
Carrier Weight (f) t	16~22

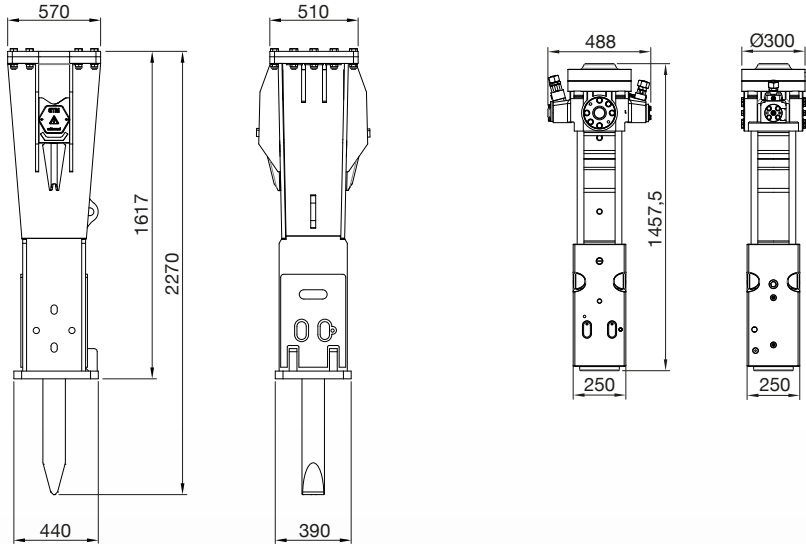

(a) It includes the approximate weight of the breaker, bracket, standard tool and hose weights.

(b) Actual impact frequency depends on the oil flow, oil viscosity, temperature and the material to be broken.

(c) Actual pressure depends on the oil flow, oil viscosity, temperature, material to be broken and the return pressure.

(d) Input power directly effects fuel consumption. Low input power (kW) requirement means low fuel consumption.

(e) Guaranteed sound power testing results according to directive 2000/14/EC (Guaranteed dB(A)=Measured Value +3 dB).

(f) If the carrier machine is out of the optimum range, ask the carrier machine manufacturer for allowed attachment weight.

## TOOL PROPERTIES

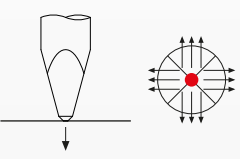
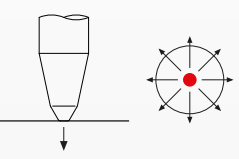
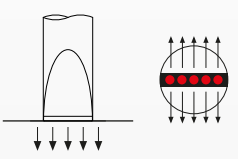
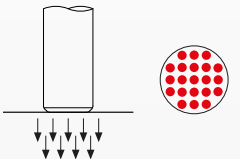
	Pyramid	Moil	Chisel	Blunt
Operating Principle				
Key Properties	<ul style="list-style-type: none"> <li>Breaking in four directions</li> <li>General demolition</li> </ul>	<ul style="list-style-type: none"> <li>Breaking in all directions</li> <li>Suitable for general use</li> </ul>	<ul style="list-style-type: none"> <li>Breaking in two directions</li> <li>Suitable for general purpose by demolition</li> </ul>	<ul style="list-style-type: none"> <li>Good energy transfer</li> <li>Demolition – Impact breaking</li> </ul>

## SPECIAL TOOLS

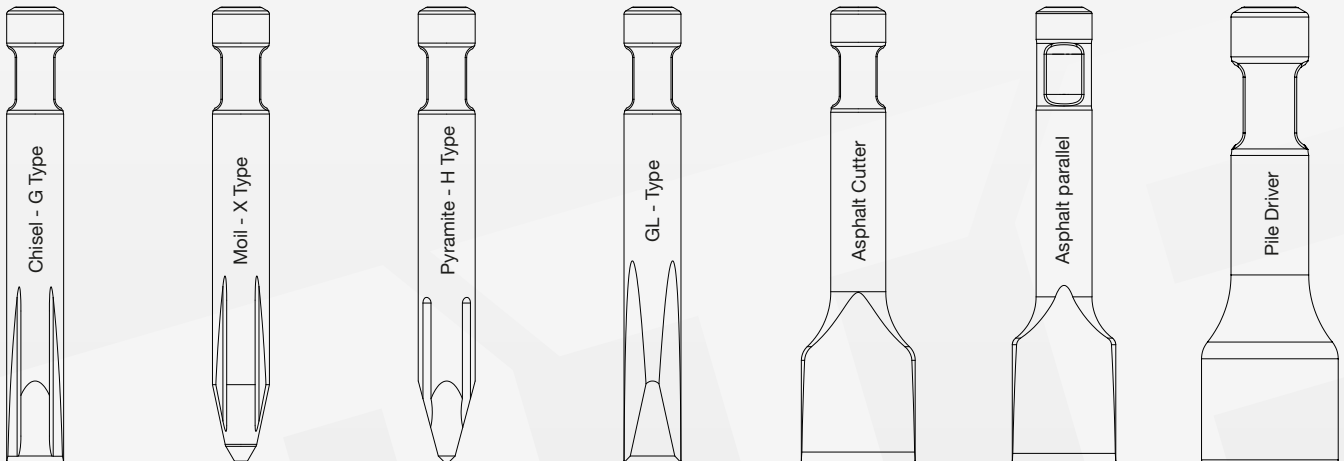

Rev. 150822



### Factory

Bahçelievler OSB Mh. 11. Cd. No: 4A

59510 Kapaklı / Tekirdağ - TURKEY

+90 282 768 25 00

[www.mtbbreakers.com](http://www.mtbbreakers.com) - [info@inanmakina.com](mailto:info@inanmakina.com)



**inan makina®**  
SANAYİ VE TİCARET A.Ş.

**MTB®**  
BREAKERS & ATTACHMENTS

**WARNING!** The visuals and the information in this brochure are standard or optional depending on the version of the product.

İNAN MAKİNA A.Ş. saves the right to modify the values and designs shown in this brochure without notice.